



# Covenant University

Canaanland, Km. 10, Idiroko Road, Ota, Nigeria. Tel: +234-1-7900724, 7901081, 7913282, 7913283

*Public Lecture Series*  
Vol 1, No. 25, January 2009



## **EFFECTIVE UTILIZATION OF RAW MATERIALS FOR DEVELOPMENT: CHALLENGES AND PERSPECTIVES**

*Frederick Kofi Hymore*

# Public Lecture Series



---

## **EFFECTIVE UTILIZATION OF RAW MATERIALS FOR DEVELOPMENT: CHALLENGES AND PERSPECTIVES**

---

**Frederick Kofi Hymore Ph.D**

Department of Chemical Engineering  
Covenant University, Ota.

Corporate & Public Affairs Department  
Covenant University, Km. 10 Idiroko Road, Canaanland,  
P.M.B 1023, Ota, Nigeria Tel: +234-1-7900724, 7901081, 7913282,7913283.  
Website: [www.covenantuniversity.com](http://www.covenantuniversity.com)

Covenant University Press  
Canaanland, Km. 10 Idiroko Road, Ota, Nigeria.

**ISSN 2006...0327**  
Vol. , 30th January, 2009



**Frederick Kofi Hymore Ph.D**

*Department of Chemical Engineering  
Covenant University, Ota.*

# **EFFECTIVE UTILIZATION OF RAW MATERIALS FOR DEVELOPMENT: CHALLENGES AND PERSPECTIVES**

## **SYNOPSIS**

Nigeria, like many developing nations, has depended on the export of her largely unprocessed raw materials for their foreign exchange earnings. The economy is as a result subject to the fluctuations of the international markets. A more effective way of using the raw materials (from agricultural to mineral) is to transform them into higher-value semi-finished and finished manufactured products for both the local and international markets. This will give us a broad-based and more resilient economy, providing domestic employment and other positive spill-over effects into other sectors. No wonder the Africa Union (AU), the UN Economic Commission for Africa (UNECA) and the UN Industrial Development Organization (UNIDO) when the UN Secretary General, Mr. Ban Ki-Moon on 'Africa industrialization day' in November 2008, urged all African countries to renew with more vigour the transformation of our raw materials in order to increase our mere 1% contribution to the world trade in manufactured goods and thus help alleviate poverty on the continent.

To do this at a rate near that of the Asian tigers will require a nationalistic leadership prepared to push through a coherent programme targeting at least initially, the agri-business and agro-processing where about 50% of the people are involved as well as infrastructure. This will involve giving a heavy science and engineering bias to our education, the acquisition and adapting of technology and the attraction of capital for specific areas of the economy.

The present state of affairs where the science and technology

structures (largely academia in the universities and research institutes) are almost tangential to industry is untenable. Much more interaction and national direction is required so that the science and technology structures and industry can feed on each other. Inadequate funding of research and development in our universities and research institutes constitutes a dreadful waste of resources. The work is 'half' done, the researcher is frustrated and the society begins to feel it serves no purpose.

The role of government is really crucial, not just in giving a sense of direction and commitment to the transformation but also in protecting local industries against the WTO (world trade organization) types of agreements that the *Bad Samaritans* have and will continue to use to try to keep us in our state of underdevelopment. They did that for their infant industries in the past and continue to do so in various sectors even now. They should not *remove the ladder* when it is our turn. If only Nigeria can direct its huge earnings to this national transformation process!

## **EFFECTIVE UTILIZATION OF RAW MATERIALS FOR DEVELOPMENT: CHALLENGES AND PERSPECTIVES**

### **INTRODUCTION:**

Raw materials can be simply defined as unfinished goods consumed by a manufacturer in providing finished goods. Hence they range from agricultural raw materials such as cereals and cotton to mineral ores such as bauxite, gold ores and crude oil. A common feature of the developing countries of the world, many of which are in Africa, is that they are primary commodity producers. Nigeria is no exception. Our raw materials are exported without any significant transformation, as primary raw materials.

In Japan there is a law regarding the effective utilization of resources<sup>1</sup>. There, the Effective utilization of raw materials refers to the total use of the raw material. This encompasses not only the transformation of the raw material into products (right from the design stage), but also the recycling of the product made from the raw material in order to create a sustainable environment. In this lecture, the term Effective utilization is used in the more restricted sense of the word—that is, better use of the raw material by obtaining more value for it. Effective utilization of raw materials, simply put, refers to their transformation into higher-value-products before they are sold. This involves the transformation of the raw materials into manufactured commodities. Apart from the higher value, it has several positive ramifications in various sectors of the economy. The processing of raw material to obtain semi-finished and finished products is a necessary step in the industrialization of any nation. Without this step, Africa and hence Nigeria will remain the 'hewers of wood and the fetchers of water' in the international context. The UN Industrial Development

Organization's (UNIDO) theme for 19<sup>th</sup> Africa Industrialization Day 2008<sup>2</sup> was "Processing raw materials for industrial growth and development". The report emphasized the following:

- Africa cannot afford to remain a primary commodity producer-raw materials that others transform into products which we then buy
- There is a crucial need for enhanced raw material transformation into manufactured products.

Without this we cannot generate the income and employment necessary to overcome poverty on the continent where many live on less than one US dollar a day. Presently Africa's trade has been concentrated in primary commodities. As a result, Africa's contribution to world trade in manufactured commodities is only about one percent. Yet this industrialization process is what will give us a broader-based economy. Perhaps it needs no reminder that no commodity, not even gold or almighty crude oil, is safe from the vagaries of the market forces of the world. The recent drop in value of the price of crude oil from about one hundred and forty nine US dollars to less than forty US dollars per barrel and its effects on the 2009 Nigerian budget should be a quick re-awakening to us all in Nigeria. The joint statements by the Africa Union (AU), the UN Economic Commission for Africa (UNECA) and the UN Industrial Development Organization (UNIDO) simply echoed that of the UN Secretary General, Mr. Ban Ki-Moon<sup>2</sup>:

"There is a need for renewed and intensified efforts to produce and trade in finished and/or semi-finished products which, as the experience of the Newly Industrialized Countries (NIC) has shown, yield higher returns and generate the resources required for accelerated industrial development."

The emphasis on the word renewed is mine. This is because we have tried it in the past and should do so again, with more energy and coordination, learning from our mistakes and the successes of others. We need not restrict ourselves to producing just for internal consumption. The Newly Industrialized Countries (NIC) even



imported raw materials, processed them into higher-value products which they exported, the net income generated further industrialization.

#### Advantages of higher-value products

Crude oil, the major primary commodity exported by Nigeria and also her major foreign exchange earner will be used to illustrate the advantages some degree of processing of our raw materials. Fig.1 illustrates some of the range of products that can obtained by the processing of crude oil-natural gas, gasoline or petrol, diesel oil, kerosene, jet fuel, lube oil, wax, asphalt, and fuel oil. Every single one of these products is needed in Nigeria. Every time our crude is exported we not only lose the benefit of these other products from the crude, we also have to buy them back at higher cost.

The present state of neglect of the refineries that has resulted in the importation of even gasoline and other refined fuels hitherto produced by the local refineries is heart breaking for any African who is concerned about the speedy development of the continent. The Niger-Delta crisis does not explain all that is happening. It is after all, from these same regions that the export of crude is carried out.

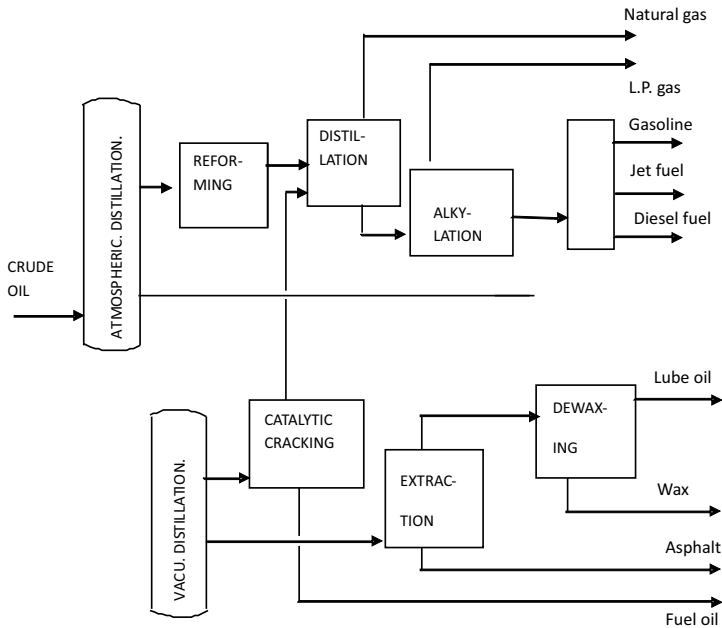

**Fig.1: Processing of crude oil to yield some of its many finished products**

In contrast to the export of these materials untreated, the processing of raw materials into these higher-value products has the following advantages:

- higher value for the products from the processed raw materials
- Increase/generation in domestic employment
- Potential application of acquired technology to other processes
- Better resilience of the economy in the face of global shocks.
- Increased independence of the country vis-à-vis its needs
- In the case of food processing, food wastage is

reduced

Although the local availability of raw materials may confer some advantages such as lower costs and better reliability of raw materials supply, the other advantages of processing them ( profit from the higher-value products and the employment processing generates) make it necessary for nations which do not have the raw materials to import and process them. These tremendous advantages explain why countries like Japan and South Korea, which do not have these materials import and process them into finished and semi-finished products.

#### Requirements for Effective Utilization of Raw Materials

It is now pertinent to discuss the requirements for achieving this and also to find out the reasons for the lack of achievement in this important area of national development

The requirements for achieving this goal of adding value to our raw materials can be classified as follows:

- Availability of requisite manpower
- Technology
- Government policy
- Capital

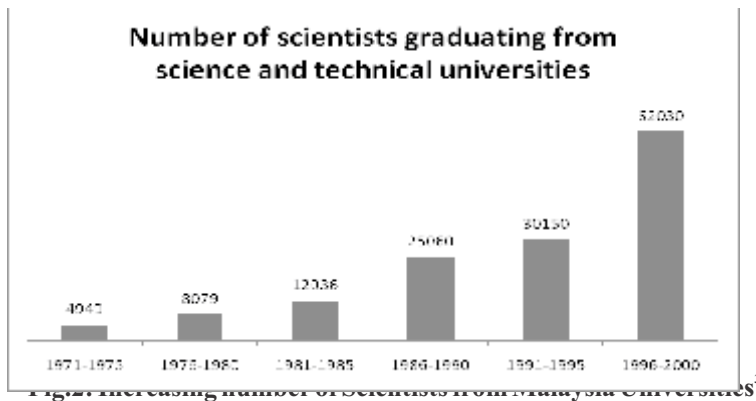

### Availability of Requisite Manpower

Requisite manpower refers to the personnel skilled in science and technology required for the transformation of the raw materials. When the Asian tigers ('four little dragons') -Hong Kong, Malaysia, Taiwan and Singapore - embarked on the policy of rapid economic transforming, they chose the radical education of their people, giving heavy emphasis to Science and Technology.<sup>3</sup>

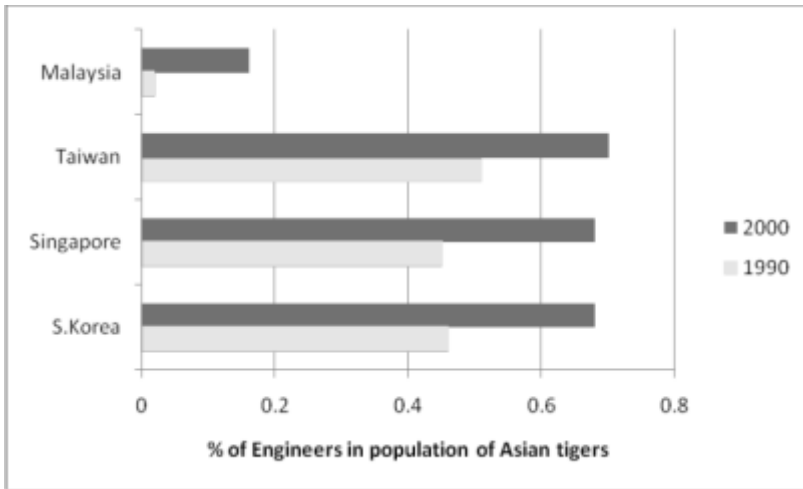

**Fig.3: Effect of educational policy on increasing number of engineers in Asian tiger population<sup>3</sup>**

As it is the case in Nigeria, the universities and technical institutes produce these personnel. It must be pointed that the heavy infusion in science and technology was borne out of a policy to excel in the shortest possible time, in aerospace, biotechnology, microelectronics, and pharmaceuticals to mention us just a few<sup>3</sup>. The net result of this policy is reflected in the data that follows.

Fig.2 shows the rapid increase in the number of science graduates produced annually as a result of this policy. Within the 30-year

period the number of such graduates jumped to more than twelve fold, representing an increase of more than 1153%!

Fig.3 illustrates the effect of the deliberate policy on the percentage of enrolment of engineers among the Asian tiger population between 1990 and 2000. The higher this percentage the more the population is ready to face the challenges of transformation of materials. Based on the data for Taiwan, Nigeria should have more one million engineers alone. How many are enrolled as engineers in Nigerian institutions?

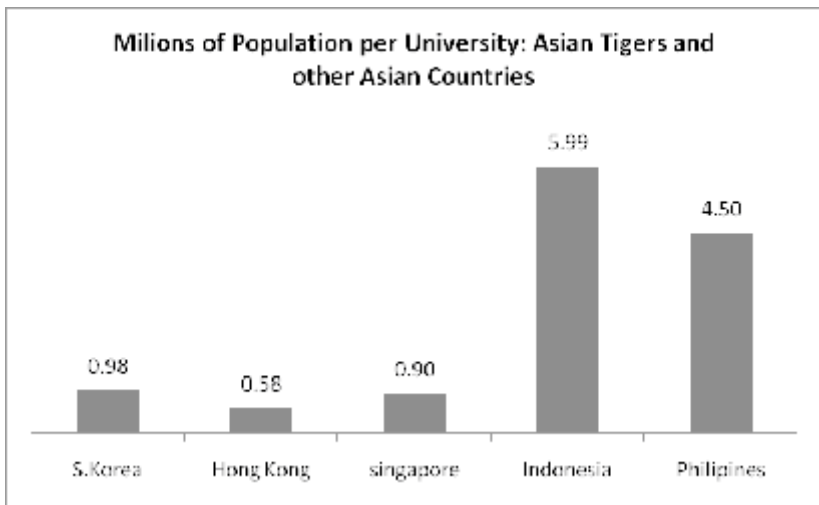
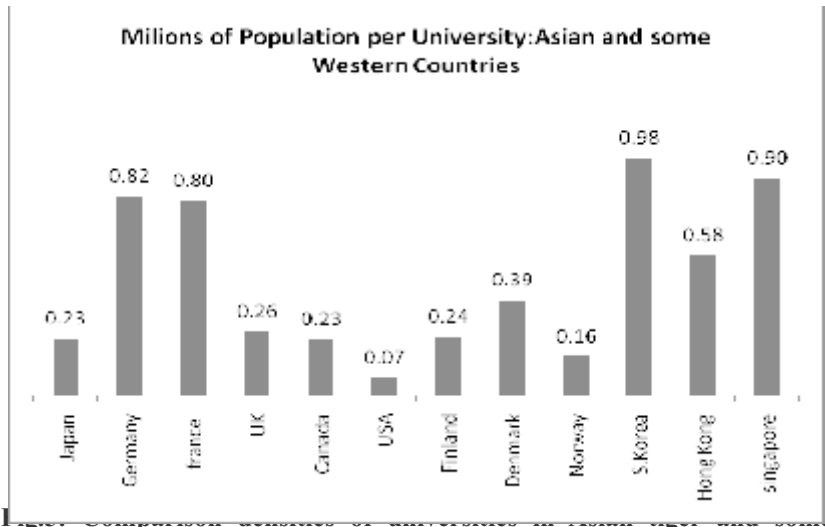

Fig.4: Density of universities in some South East Asian countries<sup>3</sup>

This heavy investment in the education of the population of the Asian tigers can also be seen from the density of universities within the population. Fig.4 compares this density among some countries in South East Asia. The lower the ratio, the more the availability of universities and colleges in a country. The much lower values among the Asian tigers (less than one million inhabitants for every university or college) contrasts with the over four million inhabitants for every university or college for the non-Asian tiger nations of the same region. This is a testimony of the

effectiveness of the educational policy of the Asian tigers. As will be seen shortly, this will be reflected in the economic performances of the countries of the region. With this density of universities among the Asian tigers as a yardstick, Nigeria will need over 150 universities just to be at par. This data is food for thought for those who think there are too many graduates roaming the streets of Nigeria. The reasons for the apparent glut of graduates in Nigeria lies elsewhere – in the inadequate planning or execution of plans. With right policies the Nigerian nation would be accelerating the programmes to increase their numbers.

Fig.5 compares the densities of universities within the Asian tiger population with those of the key developed countries of the Western World and Japan



developed nations<sup>3</sup>

The densities of universities are slightly higher than those of Germany and France in the case of South Korea and Singapore

while that of Hong Kong is even lower. Only those of Japan, USA, Finland, Canada, UK and Norway have better values. The USA has the lowest value of 0.072 millions per university, that is, 72000 people per university. Using an average value of 0.360 millions per university if that of Italy is excluded, translates into 360,000 people per university. Based on our population of 150 million, we will require to be at par, 417 universities! Rome was not built in a day!

The importance of these personnel can be seen in the relationship between the density of such skilled personnel in the developed and the newly developed countries. Although no clear statistics is available on such data in Nigeria, most will agree that we have not attained such high density of universities in Nigeria.

It is important to point out that the urgent need by Malaysia to rapidly increase the population of it science and engineering graduates was the result of a deliberate policy. They had set themselves a target and they needed this level and number of manpower to ensure success of the policy. Under Malaysian Vision 2020 (V2020), Malaysia decided to transform an agricultural-based economy into a technological-based economy. To achieve this, the Malaysia's National Science and Technology Policy (NSTP2) had the following key elements<sup>3</sup>:

- Strengthening Research and Technological Capacity and Capability,
- Promoting commercialisation of Research outputs,
- Developing Human Research Capacity and Capability,
- Promoting a culture for Science Innovation and Techno-Entrepreneurship,
- Strengthening institutional framework and management for S+T and monitoring S+T policy implementation,
- This is not the end Ensuring widespread diffusion and application of technology leading to market-driven R+D to adapt and improve technologies, and
- Build competence for specializations in key emerging technologies.

of their target! They want in addition to all their achievements a Nobel laureate in science by the year 2020, as the icing on the cake.

### Technology

Together with adequate skilled personnel, technology will provide the means and the tools for the transformation of materials into useful commodities or products. These may be acquired initially. Even the developed nations acquired technology at some stage in their development-buying spying etc. Then with a planned programme, copied and improved or even adapted to the prevailing conditions of our society.

One again, the universities and the research institutes have a crucial role to play in the acquisition and adaptation of technology. Tremendous successes like those obtained by Japan and the other Asian tigers will be possible only if a coordinated national programme towards a specific national target such as national sufficiency in, petrochemicals, rice etc. is available and is being pursued with vigour. Without such a coordinated programme, individual academicians like myself and thousands of others will make breakthroughs (activation of local clays to produce excellent bleaching agent for oils<sup>4</sup>; production of excellent resins comparable to those from the imported linseed oil was obtained from rubber seed oil<sup>5</sup>) in our little corners without it having any significant impact on the national development. These results are presented and conferences and in scientific journals, both local and international.

A similar situation exists in the research institutes where scientists and engineers toil to practicalize research findings. Two phrases best sum up the way I feel about the underdevelopment of our countries. The nursery rhyme 'things done by halves are never done right' best sums up the state of our efforts towards industrialization of Africa. We are industrializing by halves. Yet this contrasts with plans drawn up for this very purpose. Permit me to quote extracts from the mandate of the RMRDC (Raw Material Research Development Council of Nigeria)<sup>6</sup>:



The primary mandates of RMRDC are:

- To draw up policy guidelines and action programmes on raw materials acquisition, exploitation and development;
- To review from time to time, raw materials resources availability and utilization, with a view to advising the Federal Government on the strategic implication of depletion, conservation or stock-piling of such resources;
- To advise on adaptation of machinery and process for raw materials utilization;
- To provide special research grants for specific objectives and device awards or systems for industries that achieve breakthrough or make innovations and inventions; and
- To encourage the publicity of research findings and other information relevant to local sourcing of raw materials.

Even a cursory examination of the mandate of the RMRDC will clearly show an appreciation of the challenges to be faced by the country in its efforts to industrialize. Inadequate funding and the lack of political will and direction have stifled the progress that could have been made in the processing of raw materials locally. We cannot underestimate the importance of technology. Others who do not have the raw materials have copied and applied technology to bought raw materials successfully. So it is technology that is the key!

Adequate government planning

Moving a largely agricultural country to a manufacturing one within a short period requires a very committed leadership. In developing countries, governments control most of the resources. That is why their visionary policies can make a big difference to the developmental pace of the country. A clear path chosen after debates must be spelt out and pursued with a fervent patriotic zeal. Lessons from industrialization of some Asian countries revealed that industrialization was least committed in those countries which

lacked clearly argued-out positions on industrialization and self-reliance<sup>7</sup>. A report on the industrialization of the Philippines 'emphasizes that there was a large gap between the rhetoric of policy makers and the Philippines reality. A viable Science and technology policy was not a major concern of policy makers, and no serious attempt was made to introduce industrial technology. Moreover, a scientific community in the modern sense did not come into being as a functioning entity. Cultural imperialism strongly influenced the nascent Philippines scientific community, the latter often looking over their shoulders at their mentors abroad'<sup>8</sup>. If the word 'Philippines' in the report is replaced with Nigeria, most of what the report concludes can not be denied vigorously. It is no do surprise that the Philippines' is among the 'least' developed countries in south East Asia.

Although we may not be able to match the nationalistic mobilization and sacrifice of the South Koreans during their industrialization period, a clear and committed national sense of direction must be felt in order to make rapid progress. A coherent policy on industrialization in a peaceful environment is needed.

It is worthwhile to point out a little experience that serves to emphasise the role of government in any national endeavour. What shocked me most when I first visited Europe (France) were not the beautiful buildings or that most people were 'white'. I must have read about these as a student who had attained university level education. It was the radio and what they kept saying in the middle of the oil crisis of the late 1970s:

'On n'a pas de petrol mais on a des idée's'- we do not have crude oil or petrol but we have ideas (as a nation to face whatever difficulties that the petrol crisis has brought).

It was simply reminding the French that as a nation they could use their ideas to solve problems.

## **WAY FORWARD**

### **Role of Government and Self examination**

Every where in the world, governmental plans and policies have determined the pace and direction of progress especially during industrialization:

- We need to re-examine ourselves as a nation, a regional power and also in the international context and re-determine what we want for the future of this nation. A look at some of our policies does not indicate clearly where we are heading;
  - We import huge quantities of rice from south East Asia when we can vigorously pursue an active agri-business and agro-processing in order not only to be self-sufficient but also provide domestic employment.
  - Capacity utilization in many industries is below 40% and many continue to groan under the pressure of NEPA/PHC.
  - Only 5% of textiles used in Nigeria is locally produced. Yet Nigeria grows cotton and the few existing textile continue
  - We continue to import huge quantities of fuel partly because our five existing refineries can not be managed properly
  - Processing plant do not get adequate protection as they face serious competition from imported varieties of their products
  - The list can be continued.

We must seriously answer the question: do we want to be as independent as possible in providing the food and consumer goods needed by our population? If the answer is hopefully, 'yes', then we must realize that our policies are not consistent with these goals:

- We live in a very competitive world in which all countries, especially the developed and also the underdeveloped countries are striving to put themselves at an advantage. Our examination should bring out strengths and

weaknesses.

- We need to set up goals for the nation in the long term. In terms of raw material utilization, we need to prioritize areas in which we desire to attain self sufficiency or any degree of independence.
- Rigorously pursue such goals, giving adequate funding and support in order to ensure success

Our critical examination should bring out strengths and weaknesses. It should also reveal that every nation is after its own interests. That is why the USA will subsidize its farmers in order to ensure its cotton is as 'competitive' as that from a poor country like Benin Republic. No aid is 'free'. We should therefore aim to be as independent of every one as possible- producing as much of what we need as we can for both the large internal market as well as for export. This will necessarily imply processing as much of our raw materials as we can.

### **National Goals and International Competition**

The newly industrialized countries –Brazil, India, and the Asian Tigers- Malaysia, Singapore, Taiwan and Hong Kong- needed a state-directed industrialization over some relatively short period, during which efforts were concentrated towards self-sufficiency in the processing of some raw materials. In order to protect and sustain the growth of these infant industries, governments had to institute some import-restrictions and currency control measures. It is this very close government-private business cooperation termed 'Korea Incorporated'<sup>9</sup> together with favourable international climate that catapulted Korea from a largely agrarian economy to an industrialized one within two decades. 'South Korea's Industrialization had nothing to do with new inventions or any new ingenious ideas. It was all about good business. They took technologies and economic ideas from the already developed countries and employed them in their own country'<sup>10</sup>. This high “uncertainty avoidance” path (innovation, not invention) ensured

their steady progress.

In my view, Nigeria like all developing countries should stop this whole sale acceptance of 'free world trade' agreements. The developed countries are free to export their finished products to our markets which are hungry for such products because we do not produce them. We do not have higher-value products to export to them. We have been made to agree to the free importation of the food we eat. This reduces our ability to feed ourselves, destroying the income of our farmers who have sustained us over the years. The recent shortfall in rice availability, occasioned by the use of rice and other grains by the developed countries for bio fuels should be a reminder to all of us. After being led to allow the free import of rice from Asian countries which have had a longer experience in and better technology for rice cultivation, the local rice production suffered. The Nigerian government understandably panicked not just because of the price increase but as also because of the shortage of alternative sources.

### **Initial Areas of Concentration**

The Nigerian needs to sit down and decide, after appropriate consultation with all stakeholders, on immediate areas where self-sufficiency is to be attained as and also plan for the longer term. In south Korea the first, of a series of five-year plans, focused on agriculture and infrastructure before shifting to construction and light industry, and then much later focused on electronics, chemical industries and heavy industry<sup>15</sup> This emphasis on agricultural self-sufficiency is another significant feature of all the Asian tigers that is worthy of note. More than half of Africa's people are employed in the agricultural sector. This makes it essential to develop the agri-business and agro-processing industries so that food self sufficiency is assured. Given the headache caused by NEPA (National Electric Power Authority)/PHC (Power Holding Company) to industry in particular, and other sectors of the economy as well as our

dependence on imported rice and flour, it makes sense to focus on agriculture and infrastructure (steel production included) as the first area.

Lagos state is embarking on a belated but necessary rail infrastructure. Not much imagination is required to estimate the huge amount of steel that will have to be imported to meet this demand in order to realise the necessity of steel production in this early phase of concerted industrialization. In Brazil, government took charge of the provision of the infrastructure and heavy industry, the private sector was in charge of the production of consumer goods while foreign capital was in charge of durable goods such as automobiles<sup>15</sup>

#### Capital

For the rapid pace of industrialization desired, the mobilization of capital can not be restricted to internal sources alone. Foreign inflow of capital into selected areas of the economy should be welcome and encouraged with the appropriate incentives. The emphasis should be on real mutual benefit instead of benefit to the investor alone. Agreeing to the setting up of a greenfield investment (investment that creates an entirely new business) with the open or covert intention of copying/learning for future purposes is entirely in order and is to be preferred over brownfield investment<sup>13</sup> (where a foreign investor buys an existing business). This obviously requires careful and purposeful planning in order for Nigeria to benefit from it. Recent events have shown that state intervention in order to direct or sometimes support the economy should not be shied away from by government which controls most of the resources of the countries. A way however, should be found because of the poor management record of government in business in Nigeria, to subsequently disengage from it. South Korea benefited particularly from the 'contention belt of capitalist countries' which was strung around communist China and received a lot of aid from the USA. The USA financed 70% of all imports of commodities South Korea from 1953 to 1960<sup>16</sup>.

## **Research and industry in Nigeria**

It often appears that industry and research are not related at all in Nigeria. Industries get established in Nigeria and any difficulties they encounter are sent to their mother companies abroad for solutions. Researchers in the universities and research institutes struggle with the inadequate resources made available by government. The situation becomes even more difficult when it comes to the transition from the bench scale to the pilot plant scale—often an indispensable step required for large scale production. Private industrialists are often disinterested or are not ready to commit capital needed to achieve this. When significant findings are made or recommendations about some locally available raw material are made known, government intervention is often not vigorous enough and the status quo ante remains. The case of local versus imported bentonite which is used in the petroleum industry is a case in point. The net result is that the symbiotic relationship that should exist between the researchers, industry and government which represents the larger society is very poor. I am looking forward to the day when a new minister of Science and Technology whiles in traffic, will catch a glimpse of the headlines, 'Pet Company Says Local Bentonite Not Good Enough For Drilling, Scientist Disagrees' and he will not be idle or ignore it. He will call the scientist and have him/her show proof of his claims or whatever requirements that are needed to make it possible. Often one gets the impression that people in authority want the status quo to remain even if it is not in the overall national interest.

Several reasons can be attributed to this:

- Lack of confidence of industry in the researcher to solve their problems

It may be a simple case of relying on what has been tested and proven (such as their mother companies). Another case of high 'avoidance of uncertainties'

- The get-rich-quick attitude of the local entrepreneur who buys today and sells tomorrow, thereby making his quick profit. The uncertainty and risks associated with industry

may not be very attractive to them

- Ignorance of some industrialists who think that an acquired processing plant is simply to be operated in the same manner using the same resources 'forever'
- Insufficient approaches of researchers to industry to explain what they can do for each other.
- Inadequate funding of government in bringing selected research findings to their logical end- industrial stage. This will be a boost not only to the researcher but also to the general public, particularly the local entrepreneur, who gets increasingly assured in the ability of the local researchers to solve problems.
- Lack of sufficient government incentives to industrialists to involve local researchers in their research. A typical industry allocates funds for R&D and this constitutes part of the production costs. Giving some incentives to the use of their R&D funds for local research may encourage them to patronize local researchers.
- Lack of any 'official encouragement' to copy and adapt acquired technology. Remember that South Korea did not invent the wheel. They copied and adapted acquired technology. This appears very strange in a country where 'originals' of virtually every product can be obtained. Just a little help is all that will be required. After five refineries, one would have thought a challenge could have been thrown to the local engineers/scientists to build a sixth one. If there is a sixth refinery, it will be done the same way- involve local engineers down to the design stage only for them to return to be operators of the plant? This brings to mind a story told me by an Indian researcher I met in France. The director of his institute went to see the then prime minister (Mrs Indira Gandhi) about a widely imported fertilizer the institute could help produce if given the enabling environment. They were given the enabling



environment and they succeeded in spite of sabotaging efforts by those who stood to lose from the ban on importation of that commodity.

These problems arise partly from the inadequacies of the relationship between industry on the one hand and the science and technology structure on the other hand. If there is no close relationship between the science and technology structures made up of academia in both the universities and research institutes and industrialists, these bodies will not feed each other. In the ideal and pragmatic case, progress made by the science and technology structures should feed industry. The lessons from South Korea and Japan should be useful to us in this regard. The Japanese put emphasis on research directly related to industry so that any innovations from R&D (research and development) directly fed industry. Today most of the R&D is within the industries themselves-away from the public glare. In the first period<sup>17</sup>, Japan was initially dependent solely on foreign personnel for S&T (science and technology) guidance. The teachers in higher S&T institutions were almost all foreigners, who were replaced gradually by locals. At a later period, the government brought academics and businessmen together to form research councils in various fields. And this industry-academic partnership helped actively in the mastery of science and technology. Again, during the third period of catching up with advanced technology, the importation of foreign technology was strongly encouraged, as importation reduced the commercial risks and uncertainties of newly created technologies. This allowed Japan to make rapid advances in the newer technology. These imports were under strong governmental guidance with regard to their effects on the international balance of payments as well as their technology composition. In the fourth and final stage, that of creative technology, a high level of R&D expenditure has put Japan on a par with the US. According to the study, the reasons for Japan's capacity for technology mastery include its high educational

standard at the beginning of industrialization, its entrepreneurial spirit, its willingness to learn new technologies and to abandon old ones, the dual structure of Japanese industry, and the guidance given to small companies by large ones.

In the case of South Korea, the science and technology structures initially were for the provision of manpower to operate and maintain industries. For the research institutes, the government invited Korean scientists from abroad to utilize them in adapting and improving imported technologies. To repatriate these scientists, special incentives were provided and the autonomy of research activities, as well as their financial support by the government, was assured<sup>17</sup>. Constant interactions continue to exist between the science and technology structures and industry even as industry grows.

### **Managing authority For Industrialization**

In all human activity, not planning to succeed implies a planning for to fail. Just like the Asian tigers, before us achieved a remarkable speed of industrialization, a central nationalistic and powerful body is necessary in order to achieve an orderly and speedy industrialization. A high level of planning is required to ensure that the activities in one sector are not defeated by decisions taken to improve another.

VW Brazil started in 1953 with the assembly of imported components. By 1959, 50% of the parts were locally manufactured and by 1961, 95% of the parts were locally produced. No such performance can be expected of PAN (Peugeot Assembly Plant Nigeria) after about thirty years of assembling because steel, a major vehicle component is not being produced in significant quantities in Nigeria. Whether PAN invited itself or it was invited by the government, this kind of investment benefits much more the investor. The arrival of PAN should have been closely linked with the development of steel industry so the major components of the car would be locally assembled. The financial savings from the

local manufacture of components as well as the jobs that would have been created as a result have been lost.

A body comprising industrialists, government and academia is needed to plan and oversee the execution of manufacturing plans.

They will decide among other things the

- areas of emphasis in the processing of materials
- where government will commit more funds in order to achieve a speedy objective,
- research findings that need to be brought to the industrial scale rapidly because of the needs of the country
- locally produced manufactured goods that need protection

## **CHALLENGES**

THE challenges we face in transforming our raw materials into semi-finished and finished are directly related to the industrialization process and can be broadly grouped as

- internal challenges
- External challenges

### **Internal Challenges**

These refer to the things we know we should have done but failed to do, and which now hamper seriously our progress as a nation. They include:

#### 1. Infrastructure.

One of the factors that facilitate the setting up and the operation of processing plants is the availability of key infrastructure such as electricity, water, railways and roads. The absence of these or the epileptic availability of particularly, electricity, increases production costs and shorten the life span of equipments. The present groaning of processing plants in Nigeria is very genuine. The case of a former student of mine comes readily to mind. Desirous of producing 'something', he designed and constructed a press for palm kernel oil extraction because of a ready market for the produce. All he then needed was space to place his equipment

and start production. Today obtaining a generator and its associated maintenance and operating costs would have had to be taken into account. The lessons and experience gained then would have been difficult to obtain if he had the same plans today. I pray two final students who plan to go into the serious processing of some readily available agricultural products, immediately after their NYSC, will not be forced to shelve their plans because of PHC.

Similar comments can be made about non-growth of railways, necessary for the cheaper transportation of heavy goods. Our roads, as a result do not last because of the heavy load they carry. My prayer is that the plans of Lagos state government will see the light day and serve as impetus for the nation as a whole.

## 2. Inadequate funding of some key sectors

The sector of most relevance in this lecture is that of research and development (R&D). What is rewarding for a researcher is see the results of his work brought to its final natural destination-industrial scale. Further studies afterwards may involve the fine tuning and improvement to the work. One can therefore say that most of the researches in Nigeria are 'half done'. They are in journals and conference proceedings on bookshelves of libraries and offices of academicians in the universities and research institutes of the nation. The transition of research findings from the bench scale to the industrial scale generally involves a pilot-plant stage where several uncertainties about the process due to the change of scale of production. This is a far cry from the small test tubes often used during the bench scale work. It is often sad that a lot of research findings of studies done here do not see the light of day. The requests for the financing of the pilot plant stage work often meet the same response-'no funds'. The situation is the same in both universities and research institutes. The satisfaction of the researcher is locked up, the confidence that the society should

derive in the ability of her researchers to solve pressing problems is absent. The symbiotic relationship that should exist between the researcher and the local entrepreneur-a necessary condition to stop the over reliance on outside expertise-is also lost. This constitutes a dreadful waste of resources of the nation. Covenant University recently took a bold step, away from this direction. We can only pray and hope that the committed resources will be richly replenished.

### 3. Protection of local industries

Observations in this country now do not show a consistent fostering of local industries. Apart from the difficulties posed by inadequate infrastructure available, local industries have to face competition from the imported varieties of their products. Because the government's hands seem to be tied by WTO types of obligations, this aspect will be discussed under external constraints.

### 4. Business Environment

Processing plants, like all businesses, need a peaceful and orderly environment to operate successfully. One can then have a good degree of certainty that invested capital will be recovered in good time. The present unstable climate in some parts of the country does not augur well for this. This situation not only increases hardships for the already existing businesses, but also serves to deter future business from coming to establish, and gives the country a bad reputation.

### 5. Nationalistic leadership

Africa, in its adjustment to self-rule, has been unlucky in its leadership quality. Many of the countries in Asia and even Latin America which have been seen as having made the successful transition from the agrarian to the technology-based society made

significant breakthroughs when they were under dictatorships. Some dictators were known to sit at meetings between top scientists and industries in order to be abreast with the progress being made in industry. Open nationalistic interest by the leadership has a band wagon effect on followers and they are prepared to make the sacrifices to ensure success of the set goal of the nation. Until 1987 strikes were illegal in South Korea. Industries took advantage of the low wages to make rapid progress. Time will not permit the listing of the many sacrifices workers in South Korea had to make in order to make 'Korea incorporated' succeed.

Committed nationalistic leadership also comes in play when the nation faces pressures from the rich, already developed countries, who will invariably seek, through various methods, to make the 'infant' industries face unfair competition from the external market. It takes good and knowledgeable leadership to know its own interests and also fight to maintain it. They can ban selected imports or even raise tariffs, give export bonuses just to ensure the local industries survive. What has happened recently in the financial markets shows that when it comes to their national interests, theories or dogmas can be waved aside. The USA has intervened to bail out banks and automobile companies because it is not in their national interest for these national assets to fail. They fear the ramifications of such failure on their economy as a whole. Yet they complain of protection when other governments protect their industries.

### **External Challenges**

These stem from attempts by the rich countries through one to one negotiations or through international bodies like the IMF or WTO agreements which constrain the underdeveloped countries to open their markets to their goods—both manufactured and agricultural. The 'infant' industries in the under developed countries as a result suffers. The former head of state of Ghana, J. J. Rawlings, attributed the recent rice crisis to the rich countries which forced

them, in the name of free trade, to open their markets to imported rice instead of allowing or encouraging them to develop their own rice industry.

In his book, *Kicking away the ladder*<sup>11</sup>, Korean economist Ha-Joon Chang also argues, based on economic history, that all major developed countries— including the United Kingdom – used interventionist economic policies to promote industrialization and protected national companies until they had reached a level of development in which they were able to compete in the global market, after which those countries adopted free market discourses directed at other countries in order to obtain two objectives: to open their markets to local products and to prevent them from adopting the same development strategies which led to the developed nations' industrialization.

The truth of the matter is that the economic competition we are involved in is not a fair one. One of the few times, a competition between the USA and BENIN may be considered fair is in competitions like football where it is a question of pure talent and training. Even here, it can be argued that it is not completely fair but it is generally accepted that the gap can be easily bridged in this area. The developed countries know this but they still refuse to grant us sufficient concessions to enable us catch up fast. It is being argued that the WTO DOHA DEVELOPMENT ROUND<sup>12</sup> which failed would have cemented developing countries as 'hewers of wood' for the rich countries. According the deal, the developing countries basically would have to abolish their industrial tariffs and other means to promote trade. That means the current division of labour would be frozen and the poor countries would not be able to industrialize.<sup>12</sup> Only Nigeria and a few other developing countries which earn a lot from oil, with the right, policies stand a good chance of breaking from this strangle hold of the rich countries.

This story<sup>13</sup> about a now famous automobile company which was in its early years a Manufacturer of textile machinery also serves to illustrate the necessity of government support for infant

industries, the need to improve whatever technology that is acquired and the fact that industrialization is never smooth and that perseverance is required. After a lot of government support including being bailed out by the central bank in 1949, (as a form of government support), the company, Toyota motor company, and also probably the nation, Japan, proudly sent its first export of cars to the USA in 1958. It had been manufacturing poor copies of cars made in the rich countries. The car was just a cheap subcompact (disdainfully described as "four wheels and an ashtray"). To cut long story <sup>14</sup>, the car failed and it had to be withdrawn from the market. But the government felt that as a developing nation in Asia, it needed to have an automobile plant to make its development more complete. So it gave Toyota more support. Today, the American giants of the auto industry have gone cup-in-hand to the American government for funds in order to save them from bankruptcy, largely because of fierce competition from Toyota and other Japanese automobile companies which have been making more efficient automobiles. After the shame, even some Japanese wanted the car industry scrapped and instead concentrate on their silk export-the same kind of remarks one would expect if it had happened in Nigeria. Where would Toyota have been today without the government support of the past?

## **RECOMMENDATIONS**

I make my recommendations with mixed feelings. I believe Nigerians are intelligent. If we are led the right way and with GOD on our side, the sky is the beginning, as we say here in Covenant University. A lot of my recommendations a just basic common sense that we apply in our personal daily lives. I pray that we apply this in our national industrial pursuits:

- Nigeria needs to re-assess the present global situation and understand that the rich countries are "bad Samaritans" who talk about helping us but who would rather prefer we stayed underdeveloped



- Nigeria should heed more seriously, the recommendations of the UN, UNECA and UNIDO that 'we need a change' to a more effective utilization of raw materials. That is, process them into higher-value products, giving us a broader-based economy, increased domestic employment opportunities and more
- For effective utilization of raw materials, education must have a heavy bias in science and engineering, technology acquired must be critically studied for application to other processes and a leadership dedicated to ensuring the success.
- Much closer relationship between scientists in the academia and research institutes on the one hand and industry on the other is necessary so that they feed each other.
- Special funding must be given for the rapid development of specific raw materials or products to the industrial stage
- Nigeria should face challenges to its development, from within and without, with an organized nationalistic approach.
- We desist from the partial funding of research. The researcher gets frustrated, funds are lost, aim is not achieved and as a result some think it is not worth it.
- The copying/adapting of acquired technology should be officially encouraged so that they can be applied to other processes
- More efforts in eliminating the mismanagement of funds for projects

### **Acknowledgement**

I wish to express my sincere thanks to the Almighty God for giving to the Chancellor, Dr David Oyedepo, the vision that has enabled the founding of this citadel of learning, Covenant University. Going against the trend is difficult in any field of endeavour, in any

society. I therefore join all staff in thanking the Almighty God for the tremendous progress that has been made and for the greater future that is ahead of the university. I therefore feel honoured to have been called upon by the Vice- Chancellor, Prof. Aize Obayan, to give the first public lecture of the year 2009.

I wish to also thank, for their encouragements my many colleagues, especially Conrad Omonhinmin and Shola Oshunkoya who found time to check for errors.

To the entire guests, especially those I have never met but invited because of matters of interest to our continent, I say a big thank you. May the Lord bless you all even as we strive to improve our dear Nigeria in our various capacities! Amen!

## **REFERENCES**

1. <http://www.env.go.jp/en/laws/recycle/06.pdf>
2. Ban Ki-Moon, 19th Anniversary Celebration of the Africa Industrialization Day (AID) November 20, Accra, Ghana.
3. [Allafrica.com/stories/200711230526.html](http://Allafrica.com/stories/200711230526.html)
4. Hymore, F. K. and Iyayi, A. F., "Use of Local Clays in the Refining of Palm Oil", *Journal of the Nigerian Society of Chemical Engineers* 8 (2) (1989) pp.161-171.
5. Hymore, F.K. and Audu, T.O.K., "Studies on the drying of rubber seed oil-based medium alkyd resin", *Nigerian Journal of Engineering Management*, Vol.3, No.1 (2002) pp.31-38
6. [www.rmrdc.gov.ng](http://www.rmrdc.gov.ng)
7. <http://www.unu.edu/unupress/unupbooks/uu04te/uu04te10.htm>
8. S. Chamarik and S. Goonatilake (Editors) *Technological independence - The Asian experience*, United Nations University Press, 1994, Tokyo, Japan
9. <http://www.state.gov/r/pa/ei/bgn/2800.htm#history>
10. [http://findarticles.com/p/articles/mi4256/is\\_5\\_21/ai\\_82556559/pg\\_2](http://findarticles.com/p/articles/mi4256/is_5_21/ai_82556559/pg_2)
11. Ha-Joon Chang, *Kicking Away the Ladder – Development*

- Strategy in Historical Perspective Anthem Press, 2002, New York
12. [http://www.wto.org/english/tratop\\_e/dda\\_e/dda\\_e.htm-25k](http://www.wto.org/english/tratop_e/dda_e/dda_e.htm-25k)
  13. Ha-Joon Chang, *Bad Samaritans – Rich Nations, Poor Policies, and the Threat to the Developing World*, Random House, (2007).
  - 14 <http://citizenandreas.blogspot.com/2008/12/misunderstaning-ha-joon-chang.html>
  15. [Http://www.industrialization/uu04te10.htm](http://www.industrialization/uu04te10.htm)
  16. Baer, Werner (1972), "Import Substitution and Industrialization in Latin America: Experiences and Interpretations", *Latin American Research Review* vol. 7 (Spring): 95-122.(1972)
  17. <http://www.unu.edu/unupress/unupbooks/uu04te/uu04te10.htm#philippines>
  18. <http://www.unu.edu/unupress/unupbooks/uu04te/uu04te0f.htm#research%20and%20development>



Designed and Produced by Corporate & Public Affairs Dept., Covenant University, Km. 10 Idioko Road, Canaanland, P.M.B 1023, Ota, Nigeria Tel: +234-1-7900724, 7901081, 7913282,7913283.

Website: [www.covenantuniversity.edu.ng](http://www.covenantuniversity.edu.ng)